

**PROJECT - BUILDING PLAN**  
 PROJECTED BY: STREIGHT LINE ARCHITECTS PVT. LTD. 11 RESIDENTIAL BUILDING AT BHUBAN CHANDRA BHAR MAIN ROAD, R.S. KHATIAN NO. 25, L.R. KHATIAN NOS. 232, 234, J.L. NO. 01, SHEET NO. 16, ROAD NO. 15, P.R. - MOUSA, CHAMRANGAL UNDER CHANDERNAGORE MUNICIPAL CORPORATION DISTRICT - HOOGHLY.

ITEM	R.S. DAG NO.	L.R. DAG NO.	HOLDING NO.
LAND	53 (7)	M. 2686, 99	1428
POND	49	87, 99	1428

**OWNER NAME:-**  
 1. MR. KAUSHIK PANDA, S/O: MR. DIGAMBAR PANDA  
 2. MR. ANANDARAM ROY, S/O: MR. SHYAM KUMAR ROY

**TITLE - BUILDING PLAN**

**DRG. NO. - PK20282CORP041**

**DATE - 15.01.2025** **DRAWN BY - R.K.**  
**JOB NO. - PK01** **CHKD BY - P.K.**

**DESIGNED BY - STRAIGHT LINE CORPORATION**

**AREA STATEMENT**  
 LAND AREA - AS PER PHYSICAL  
 AREA OF THE PLOT - 16,124.14 SQ.M. (3697.50 SQ.FT.)  
 AREA OF THE POND - 114.00 SQ.M. (2550.00 SQ.FT.)  
 AREA OF THE LAND - 16,010.14 SQ.M. (3547.50 SQ.FT.)  
 OFFICE AREA - 12.24 x 8.02 FT. (368.50 SQ.M. / 8025.00 SQ.FT.)  
 REST AREA OF THE LAND - 18.94 x 9.04 - 14 SQ.M. (155.43 SQ.M. / 3359.92 SQ.FT.)

**COVERED AREA:-**  
 GROUND FLOOR COVERED AREA - 602.31 SQ.M. (1300.00 SQ.FT.)  
 TYPICAL (1ST-7TH) FLOOR COVERED AREA - 703.50 SQ.M. (1517.00 SQ.FT.)  
 TOTAL COVERED AREA - 5613.39 SQ.M. (12042.00 SQ.FT.)

**SERVICE AREA AT GROUND FLOOR - 253.50 SQ.M. (5450.00 SQ.FT.)**  
 COMMERCIAL AREA AT GROUND FLOOR - (INCLUDING 2 NO. STAIR & LIFT)  
 CAR PARKING AREA AT GROUND FL. - 271.74 SQ.M. (5850.00 SQ.FT.) (18 NOS.)  
 2 NOS. STAIR COVER & LIFT SHAFT ROOM AREA - 160.00 SQ.M. (3437.50 SQ.FT.)  
 OFF STREET CAR PARKING AREA - 225.00 SQ.M. (4837.50 SQ.FT.) (18 NOS.)  
 HEIGHT OF THE BUILDING - 25.00 M FROM GROUND LEVEL

**SPECIFICATIONS:-**  
 ALL DIMENSIONS ARE IN MM UNLESS OTHERWISE SPECIFIED.  
 ALL EXTERNAL WALLS ARE 200 mm THICK.  
 ALL INTERNAL WALLS ARE 100 mm THICK UNLESS OTHERWISE SPECIFIED.  
 ALL OTHER SPECIFICATIONS CONFORMING RELEVANT IS:11 CODE.

**DECLARATION OF ARCHITECT:-**  
 I HEREBY CERTIFY THAT THE DESIGN AND CONSTRUCTION OF THE PROPOSED WORK AS SHOWN IN THE DRAWINGS AND SPECIFICATIONS ARE IN ACCORDANCE WITH THE RULES AND REGULATIONS OF THE MUNICIPAL CORPORATION, HOOGHLY AND THE BUILDING ACT, 1956 AND ALL OTHER APPLICABLE LAWS AND REGULATIONS.  
 I, THE ARCHITECT, HAVE NOT BEEN ADVISED BY ANY OTHER PARTY THAT THE PROPOSED WORK IS SUBJECT TO ANY OTHER LAWS OR REGULATIONS.  
 I, THE ARCHITECT, HAVE NOT BEEN ADVISED BY ANY OTHER PARTY THAT THE PROPOSED WORK IS SUBJECT TO ANY OTHER LAWS OR REGULATIONS.  
 I, THE ARCHITECT, HAVE NOT BEEN ADVISED BY ANY OTHER PARTY THAT THE PROPOSED WORK IS SUBJECT TO ANY OTHER LAWS OR REGULATIONS.

**strightline**

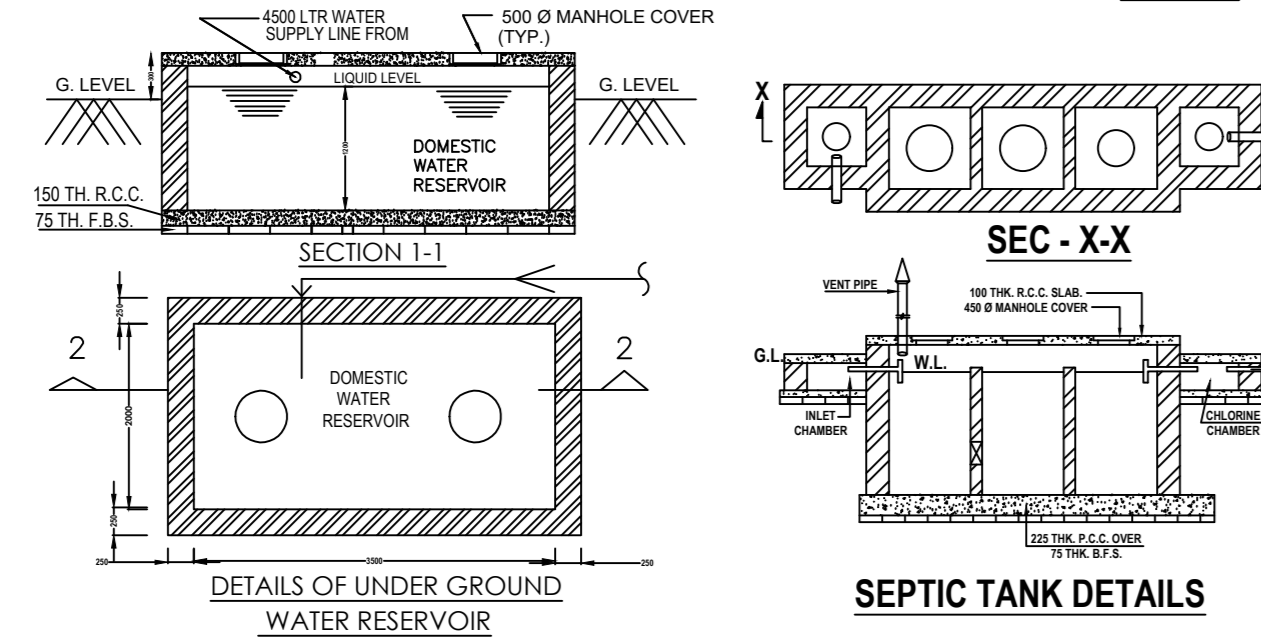

**SCHEDULE OF DOORS AND WINDOWS**

DOORS SCHEDULE		WINDOWS SCHEDULE	
MKD.	SIZE	MKD.	SIZE
D	1500 x 2100	W1	1500 x 1200
D0	1050 x 2100	W2	1200 x 1200
D1	900 x 2100	W3	1000 x 1200
D2	850 x 2100	W4	600 x 750
D3	750 x 2100		

